

Monika **KURPAS**  
Andrzej **SZAFRANIEC**

## VERSATILE RESCUE AND TRANSPORT VEHICLE

**Abstract.** The article presents a concept of a tracked floating vehicle intended for, inter alia, the transport of fire fighting containers to places inaccessible to ordinary wheeled vehicles. The vehicle could also be a means of evacuating people, animals and equipment from disaster-stricken areas. It would serve the services supervised by the Crisis Management Centre, including the fire brigades. The vehicle's specific features include the ability to negotiate rubbles and boggy land and to float. The container self-loading system allows for autonomy and independence of the vehicle from lifting equipment. Use of composite construction materials significantly reduces the weight of the vehicle.

**Keywords:** amphibian, fire fighting containers, natural disasters, civilian search and rescue, Crisis Management Centre.

### 1. INTRODUCTION

Preventing natural disasters and other unusual emergencies and fighting and eliminating the effects thereof is one of the many tasks facing the Provincial Crisis Management Centres. These authorities are also indirectly responsible for the implementation of activities related to monitoring, planning, responding and remediation of hazards in the provinces [1].

Hazard characteristics along with the risk assessment of their occurrence, the tasks and responsibilities of crisis management participants, and the forces and resources planned for crisis situations are described in detail in the National Crisis Management Plan (KPZK) [2]. The drawing up of the document was based on art. 5 of the Act of 26 April 2007 on crisis management (Dz.U. No. 89, item 590, as amended) [3]. Many years of experience in applying the guidelines given in this document during crisis situations and during large public events, including the UEFA EURO 2012 European Football Championships, the NATO Summit in Warsaw in 2016 and the World Youth Days in Cracow in 2016, have indicated the need to verify the Plan (KPZK), which is being done currently [1].

Among the units responsible for carrying out tasks included in KPZK are the State (PSP) and Volunteer (OSP) Fire Service. The most important actions of the fire brigades during floods are preventive and rescue evacuation of people and animals from endangered areas, protection and monitoring of the status of flood embankments and the pumping of water from flooded structures and areas. The basic process in this type of rescue actions is also the decontamination of people, animals and equipment used.

The fire brigades have no depots for storing the equipment needed to carry out preventive and rescue actions during floods and other emergencies. Fire protection units may, however, use equipment placed in containers [4] remaining at the disposal of Commands and/or deposited in Units subordinate to the Provincial Governors, including Provincial Crisis Management Centres.

The containers may also be treated as a type of mobile equipment depot. They may hold various types of equipment required during rescue operations. The problem is the availability of the

equipment at the action site. The widely used wheeled vehicles, capable of transporting, loading and unloading containers, are of little use because of mobility limited to paved roads only.

## 2. TRACKED VEHICLES FOR TRANSPORTING FIRE FIGHTING CONTAINERS

Vehicles that meet a significant part of the requirements for carrying out rapid and effective rescue operations, whether in the area of evacuation of people, property, or in the transport of all kinds of materials, are military floating transporters (PTS-M, commonly called the PTS [5]), designed mainly for logistic tasks related to the shifting of troops.

Fig. 1 shows examples of operations where PTS amphibians were used. It also confirms the necessity of possessing and using such equipment.

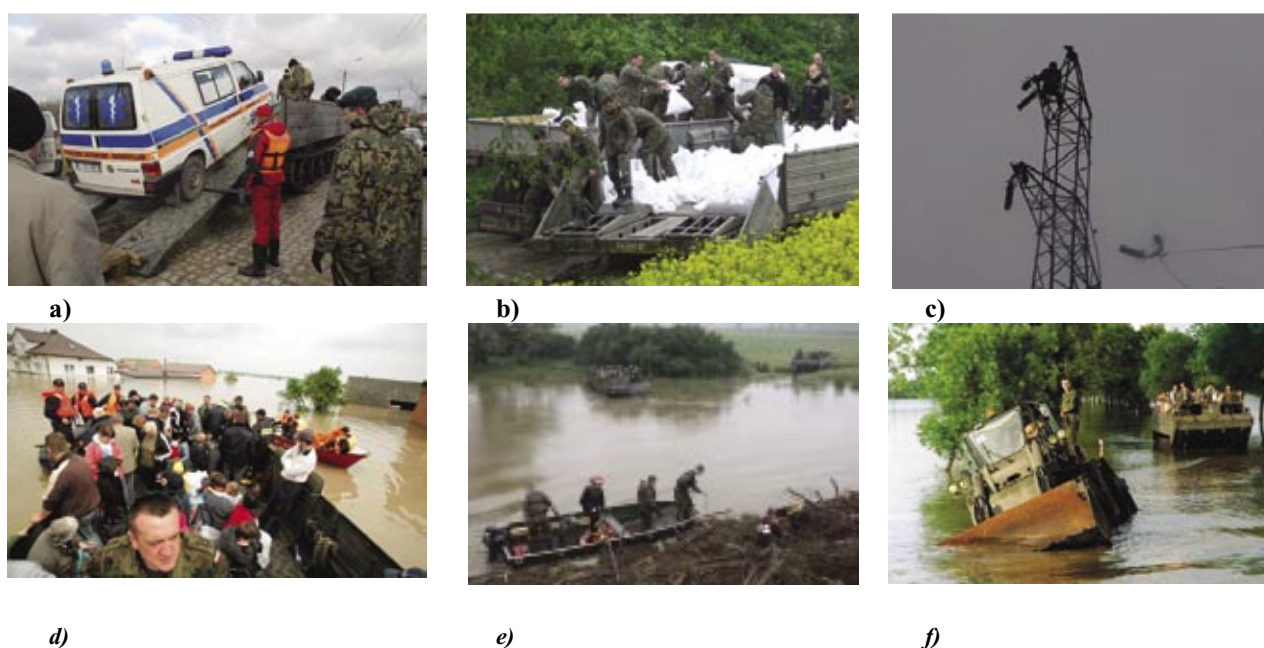

**Fig. 1. Selected operations using PTS amphibians**

- a) 2011 - military PTS amphibian over 120 times crosses a 220 metres stretch between Ostrówek and Złotów across the Gopło Lake carrying private cars, ambulances, fire vehicles, helping farmers transport livestock, grain, straw, etc.
- b) 2011 - transportation of sand sacks for embankments to places that no other vehicle (except for PTS) can reach.
- c) 2011 - due to lack of heavy equipment, the State Fire Service in the Lubuskie Province cannot transfer repair crews to power lines in the threatened area - this is done by military PTS amphibians, which in addition break ice at the base of the pillars.
- d) 2010 - evacuation of the village of Sokolniki (Podkarpackie Province). Nine PTS vehicles participate in rescue operations in the districts of Mielec, Krosno, Ropczyce-Sędziszów, Leżajsk, Strzyżów, Jasło, Brzozów, Łańcut.
- e) 2009 - regions of Podkarpacie, Lower Silesia, Opole. PTS are used in the elimination of the effects of flood in the south of Poland (particularly in the region of the Kłodzko Basin, near the towns of Jaskowa Dolna, Lewin Kłodzki, Żelazno).
- f) 1997 - flood in the Lubsza commune (Opole Province), where 100% of the commune area was covered with water and the communication routes were destroyed. PTS were used for the rescue of people and equipment (military bulldozer).

While the currently used PTS (PTS-M) military amphibians are suitable for evacuation, they fail to meet the requirements for container transport due to the inability to unload containers and insufficient carrying capacity. The carrying capacity on ground is ca. 5,000 kg, and 10,000 kg on water. As the weights of fire fighting containers vary within the range of 4,000 to 15,000 kg, only the lightweight types would be suitable for carrying on PTS amphibians. Moreover, PTS design is based on the T54 tank units, originating in the 1960s. In addition, military vehicles are provided with "rough" tracks, which cause road and pavement damage. Usually the transported equipment and materials are unloaded manually.

### 3. PRINCIPAL TYPES OF FIRE FIGHTING CONTAINERS

Flood fighting containers are part of the contents of fire fighting containers. They must meet the requirements of national regulations related to fire fighting containers defined in the Ordinance of the Minister of Internal Affairs and Administration of 27 April 2010 (Dz. U. No. 85 of 2010, item 553, Annex item 4.3.4.4) [6]. Detailed description of containers used and offered by manufacturers [4], [6], [7], [8], [9], [10], [11], [12].

Basic dimensions of the container (overall dimensions and dimensions related to the linkage with the loading device) are given in Fig. 2.

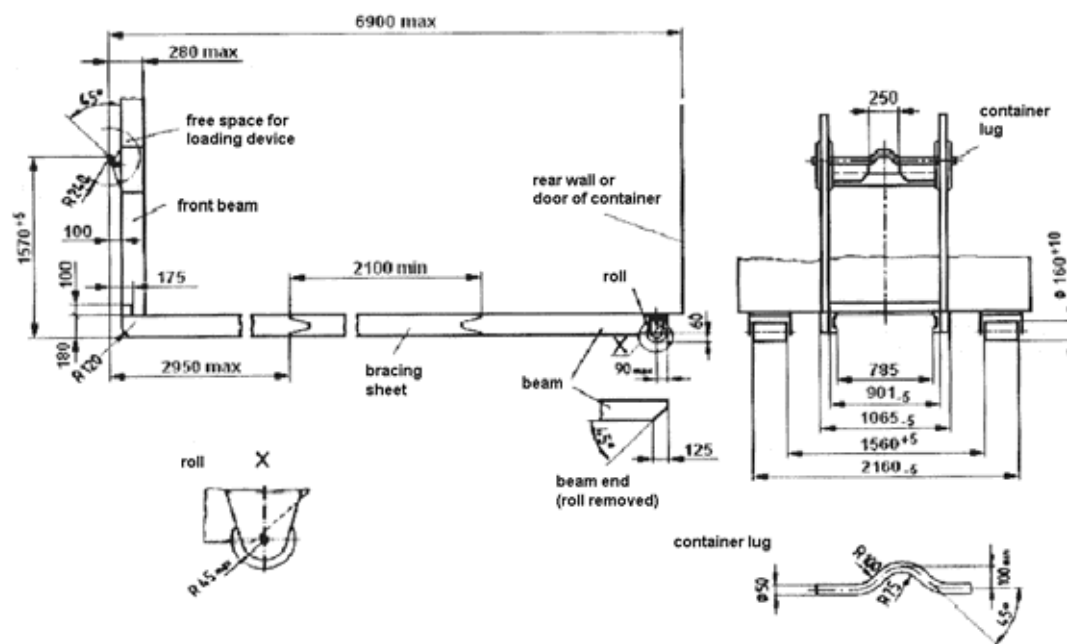

**Fig. 2. Basic dimensions of the container**

The container should also meet the requirements of EN 1846-2 in relation to equipment access, equipment chests, electrical equipment, control and monitoring equipment, accessory equipment, portable rescue equipment and corrosion resistance.

Container equipment for which the values of the characteristic parameters, the type of parameters and the limit values and the type of equipment are not specified are determined by the user according to its needs.

Standards for the equipment of flood fighting containers were established as part of the "Guidelines for the Standardization of Fire Vehicles and Other Means of Transportation of the State Fire Service" issued by the Headquarters of the State Fire Service [8].

In 2012 there were three standards for the equipment of flood fighting containers:

1. KPPm flood fighting containers with dirty water pumps [9].
2. KPPŁ flood fighting containers with boats [10].
3. KPPZ flood fighting containers with barriers [11].

Other types of containers are also in use (for fighting other hazards), such as:

- fire extinguishing,
- command and communication,
- hose,
- medical,
- chemical emergency response (decontamination),
- environmental emergency response,
- respiratory protection equipment,
- logistics,
- other (welfare, sanitary, engineering, etc.).

Some of the fire fighting container types are shown in Figs. 3 to 6:



**Fig. 3. Pump container**



**Fig. 4. Container with barriers**



**Fig. 5. Engineering container**



**Fig. 6. Logistics container**

Containers are transported on wheeled vehicles specially adapted for this purpose and fitted with loading equipment. Under the conditions of natural disasters, such as floods, vehicles of this type may not always reach the desired location, especially in marshy areas, crossed by watercourses or in flooded areas. The roads are damaged, covered with rubble, etc.

Effective mitigation of flood effects requires the provision of the fire brigades with appropriate equipment capable of travelling relatively long distances over land and water, fitted with the necessary rescue kits and basic recovery equipment. Bearing in mind that due to the variety of field obstacles or limited ground load capacity, many tasks cannot be accomplished by off-road wheeled vehicles, OBRUM has developed, within its own resources, a complete concept of a tracked amphibious vehicle capable of moving freely off the roads, in marshy land, over rubble piles and floodplains. Large open loading space (ramp) with a system for efficient self-loading and unloading facilitates the transport of equipment placed in containers.

Reviews of an R&D project proposal submitted to NCBiR (National Centre for Research and Development) (INNOTECH competition) confirm the correctness of the concept and market demand for the solution presented by OBRUM.

#### **4. CONCEPT OF AN AMPHIBIOUS VEHICLE**

The vehicle is designed to transport equipment for civil defence units, including fire brigade units, and for the evacuation of people, equipment and animals. This equipment is placed in containers and includes logistic support, pump units, lighting units, sanitary units, flood fighting equipment, fire fighting equipment, medical units and more.

The vehicle can also carry other vehicles.

The loaded vehicle should move freely in areas affected by natural disasters, i.e. off roads, in marshy areas, rubble piles, and should be capable of negotiating water obstacles (floating vehicle).

The vehicle should also be provided with a self-loading system for ISO 20' containers [13], [14], and be capable of carrying other loads on a special platform (Fig. 7).

According to [15] the vehicle should be classified as:

- amphibian,
- heavy vehicle (maximum weight over 16 Mg),
- off-road vehicle.

#### 4.1. Main specifications

Vehicle type:	tracked
Crew:	2 persons
Cargo weight:	10,000 kg
Total weight:	22,000 – 25,000 kg
Road travelling speed:	50 km/h
Drive:	hydrostatic, front
Engine:	Iveco Vector15 or similar
Motor output:	min. 400 kW (Vector15 – 540 kW)
Negotiating obstacles:	
- ditch	- min. 2.5 m
- vertical obstacle	- min. 0.6 m
- slope	- 30°
- ground clearance	- min. 400 mm
Thrust on ground:	min. 20 kN

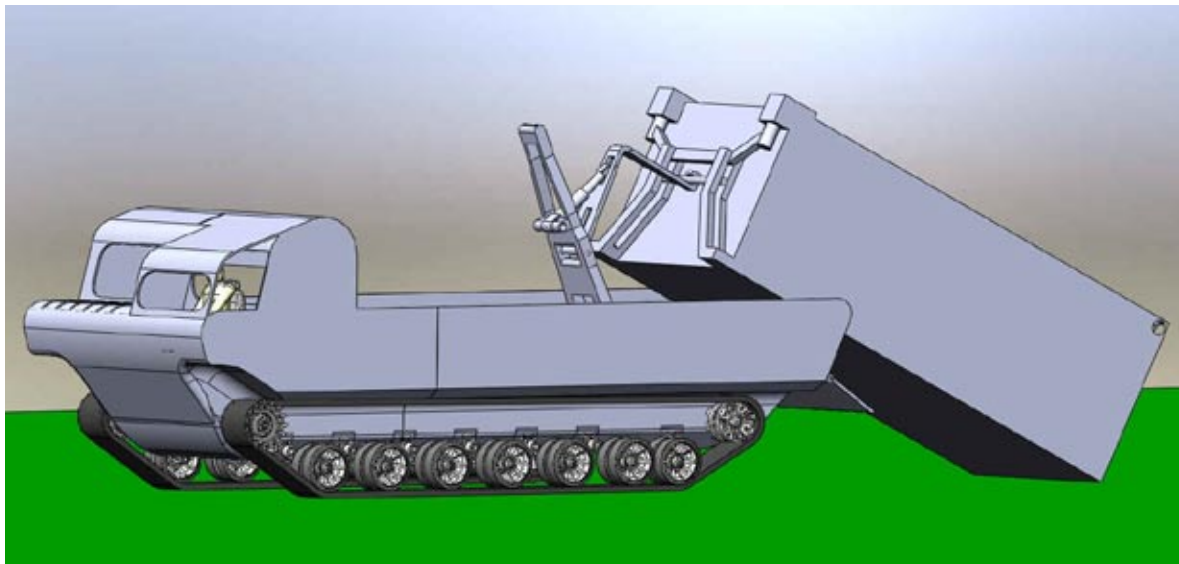

Fig. 7. Concept of the vehicle

## 4.2. Power transmission system

The power transmission system comprises:

- combustion engine,
- intermediate transmission,
- 2 traction pumps,
- 2 traction motors,
- 2 hydraulically driven propellers,
- final drives,
- drive wheels,
- tracked driving system.

The proposed main engine of the vehicle is a six-cylinder Iveco Vector15 unit with a power of 510 kW, resulting in a power to weight ratio of 21 kW/t.

The intermediate transmission is a cylindrical gear with slanted teeth. It drives 2 hydraulic traction pumps, hydraulic pump of cooling system fan drives, hydraulic pump of self-loading system and pumps of the propeller and winch. Transmission ratio for the traction pump drive is  $i = 0.84$ .

The two final drives are fixed to the sides in the front of the vehicle and they transmit power from hydraulic motors to the drive wheel and the track system. Planetary gears, single stage, with parking brake, overall transmission ratio, introductory,  $i=9$  (depending on other parameters).

A hydraulic drive system is used, in fact two systems of closed type, charged from a single tank serving the entire vehicle (Fig. 8).

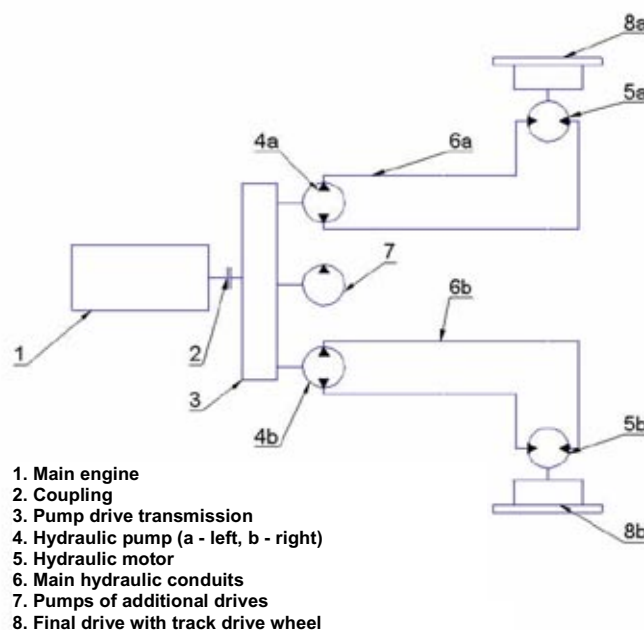

**Fig. 8. Diagram of the power transmission system**

### 4.3. Main pumps

The proposed main traction pumps are axial piston pumps Sauer-Danfoss 90P130 of the following specifications:

Speed:	500 to 3100 rpm	(max. 3400)
Pressure:	42 MPa	(max. 45 MPa)
Operating temperature:	between -40°C and 104°C	
Weight:	88 kg	

The following limiting operating parameters were adopted:

Speed:	700 – 2500 rpm
Pressure:	40 MPa
Power input:	217 kW
Pump shaft power:	250 kW

### 4.4. Traction engines

Sauer Danfoss typu 51D250-1, variable displacement, two-position, electrical or pressure controlled.

Motor specifications:

Speed at max. displacement:	2200 (2700) rpm
Speed at min. displacement:	3400 (4250) rpm
Pressure:	480 (510) bar
Flow:	300 dm <sup>3</sup> /min
Weight:	86 kg

### 4.5. Vehicle dimensions

The dimensions of the load-carrying body should ensure unhampered positioning of a 6.5 m long container (standard container with additional equipment) with a width of 2.55 m. Length of the load carrier platform: 7 m. Vehicle width ca. 3.4 m. Drive system similar to that of a caterpillar tractor, 7-wheeled. Asymmetric cab, set forward and mounted high to ensure good visibility for the operator.

Length x width x height, 10,100 x 3,850 x 3,500 (mm, height inclusive of container).



#### 4.6. Container loading system

As the containers are adapted, a hook loading system is proposed for installation on the amphibian. There is a wide variety of hooklift equipment for trucks available on the market. These are both of foreign make, e.g. Meiller Kipper, Hiab (Multilift), Hyva (Hyvalift), Palfinger (Palift), Laxo, Fornal, as well as of Polish make, e.g. HEWEA, Skibicki, KH-kipper, MWM Brzesko, Wuko Łódź, King, Janco.

Two examples of the following manufacturers are presented below: Palfinger and Skibicki.

##### 4.6.1. Palfinger

This company offers a Palift system [13] (Fig. 9), which includes several hooklift systems: Power, Giant and Synchron, depending on the type of container and chassis for installing.

Preliminary assessment indicates the Power system as the most efficient.



**Fig. 9. Palfinger Power system installed on a wheeled chassis**

The Power system features a kinematic system based on double arm inclination. Such design enables loading of heavy containers onto the vehicle chassis using rotational movements only; it ensures high reliability and durability of the installation. Another advantage of the system is its ability to lift a container positioned close to the vehicle, or even from a level lower than ground surface.

#### 4.6.2. HKS 16 - 30 hooklifts (Skibicki)

HKS 16 - 30 [14] (Fig. 10.) is designed for carrying 7000 mm containers.



**Fig. 10. HKS System (Skibicki)**

#### HKS 16-30 specifications

- rated loading power 20 t,
- maximum loading power 22 t,
- telescopic main arm, extendible length  $T = 1300$  mm,
- standard hook arm length ca. 6300 mm,
- hook arm height  $H=1570$  mm (acc. to DIN30722),
- weight 2100 - 2200 kg,
- operating pressure 300 bar,
- hydraulic lock of container acc. to DIN 30722 - external or internal,
- pneumatic control of operations - resistance to ambient conditions,
- cab control or remote control,
- a support roller (chassis on pneumatic suspension) is used to stabilize the chassis during loading and unloading,
- civilian and military approvals from the Office of Technical Inspection (UDT).

## 5. COMPARISON AND SETUP OF AN AMPHIBIOUS VEHICLE

As an ultimate goal, the new concept of a tracked floating vehicle will, as compared to PTS, provides:

- high mobility - travel over water and ground, adapted to transportation by air, sea and land (PTS is not adapted, in terms of dimensions, to the cargo space of aircraft, limitations in rail transport);
- large open loading space (ramps) adapted for transportation of ISO 20' containers and other loads on a special platform (PTS dimensions are comparable, however, the ramp space has been specially designed to allow easy assembly and dismantling of equipment/accessories. Bottom of the ramp is designed for transporting containers);
- easy change of purpose by expanding the system or by changing the type of container (comparable to PTS);
- modern design of the power transmission system, which reduces the weight - hydrostatic drive system (different system in PTS);
- container self-loading system (not present in PTS) made of various materials (metals and non-metals), including composite materials (steel only in PTS);
- ergonomic cab (standard cab in PTS);
- floatable in, for instance, river streams flowing at 1.5 m/s (comparable with PTS);
- compliance with the Ordinance of the Ministry of Infrastructure of 31.12.2002 (Dz.U. 03.32.262) and the Ordinance of the Ministry of National Defence, Internal Affairs and Administration of 9 June 2005 on the technical conditions to be met by special vehicles and special purpose vehicles (PTS not compliant);
- ability to haul flat-bottomed boats or rafts with additional equipment, e.g. flood-fighting equipment (comparable with PTS);

The ultimate equipment of the amphibian includes:

- hydrostatic drive for tracks and propellers;
- tracks of new design made of plastic material, facilitates fording;
- vehicle construction material - composite in metal frame;
- self-loading system for ISO 20' containers;
- container moving rails with optional loading system;
- suspension with friction dampers and hydraulic suspension lock (for the time of container loading and unloading);
- winch for vehicle self-rescue and for pulling other vehicles;
- power generator with independent drive for emergency power supply to on-board equipment;
- automatic water draining system;
- special lighting, i.e. search light, anti-fog lights, sound signalling, warning/alarm horns;
- communication means - modern integrated systems required for commanding.

Optional equipment depends on user's requirements or on the type of mission/operation. It should include a set of equipment necessary to provide fast support or protection of facilities and to carry out minor rescue tasks.

In the Polish market there are currently no equivalents of highly mobile rescue and transport vehicles that could support the actions of rescue and crisis management teams. The ultimate recipients of the project (after launching industrial scale production) could include Provincial Offices (Crisis Management Departments), district and commune authorities, particularly those of regions of high flood probability.

Fig. 11 shows an illustrative diagram of the initial concept of the vehicle. The concept includes separate blocks that contain the individual systems provided for in the project.

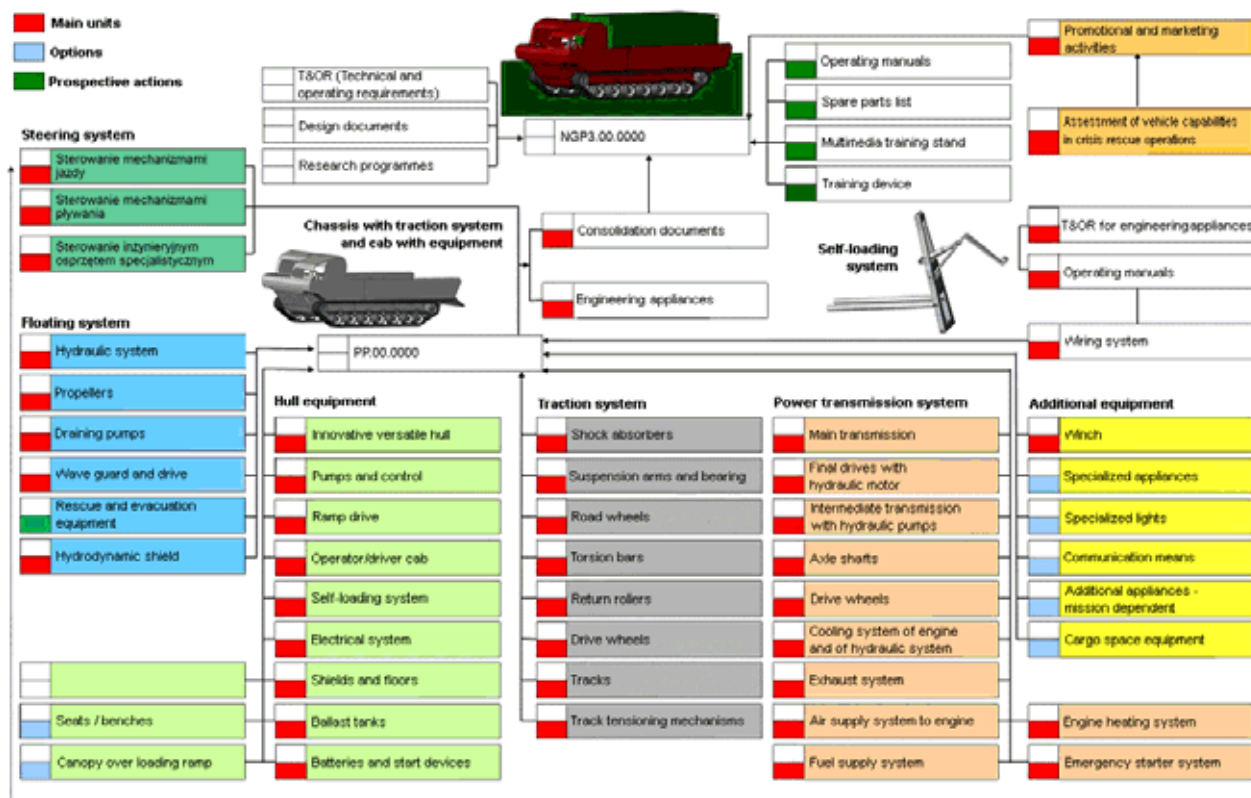

Fig. 11. Illustrative diagram of the initial configuration of the vehicle

## 6. COMPETING DESIGNS

Currently, apart from PTS (Russian ПТС - *Плавающий транспортер средний* - medium-sized floating transporter, designed in the USSR and manufactured since the 1960s in several versions: PTS (1961), PTS-M (1965), PTS-2 (1973), PTS-3 (1988)) there are only a few amphibious vehicles, such as the US amphibious assault vehicle AA7V [16] (Fig. 12) or the BAE Systems Aquatrack [17] (Fig. 13). These vehicles, however, are designed for military use in beach landing operations, are provided with armour, and are not suitable for flood rescue operations. These products were designed by the armaments industry in accordance with buyer's requirements.



**Fig. 12. US amphibious assault vehicle  
AA7V**



**Fig. 13. BAE Systems Aquatrack**

## 7. SUMMARY AND CONCLUSIONS

Among all the phases of crisis management, from prevention through preparation, response, to reconstruction, there is a need for various kinds of specialized equipment, including amphibians.

Lately, crisis situations have been occurring often, and thus the need to prepare for them in the best possible way by establishing Crisis Management Centres (CZK), also in light of the updates of the National Crisis Management Plan.

Analysis of the possibility of procuring a vehicle with the capability of self-loading/unloading and the ability to reach the designated place effectively has eliminated several proposals, mainly of wheeled design, due to the limited ability to negotiate slopes (embankments) and to cross marshy land. Efficient navigation on both water and land also eliminates solutions based on the chassis of construction machinery.

The most rational proposal of the vehicle that meets most of the needs/expectations of the fire brigades is the development of a new type of amphibious vehicle adapted to the requirements of modern civil defence.

## 8. REFERENCES

- [1] Zarządzanie kryzysowe, Rządowe Centrum Bezpieczeństwa,- <http://rcb.gov.pl/zarzadzanie-kryzysowe/> [Retrieved: 20-02-2017].
- [2] Krajowy Plan Zarządzania Kryzysowego 2013/2015 opracowany w Rządowym Centrum Bezpieczeństwa z udziałem przedstawicieli zainteresowanych organów administracji publicznej.
- [3] Act on Crisis Management of 26 April, 2007 (Dz. U. Nr 89, item 590, as amended)
- [4] Riegert D., Ślosorz Z., Radwan K., i inni: „Doraźne metody ochrony stosowane podczas powodzi ze szczególnym uwzględnieniem rękawów” Monografia. Józefów 2012. Wyd. CNB Ochrony Przeciwpożarowej im. J. Tuliszkowskiego PIB Józefów.
- [5] PTS (amfibia) - [https://pl.wikipedia.org/wiki/PTS\\_\(amfibia\)](https://pl.wikipedia.org/wiki/PTS_(amfibia)) [Retrieved: 18-02-2017];

- [6] Ordinance of the Ministry of Internal Affairs and Administration of 27.04.2010, Dz. U. No. 85, 2010item 553, Annex item 4.3.4.4.- container requirements and dimensions.
- [7] Frątczak P., Woźniak J.: „Kontenery przeciwpowodziowe” Strażak 5/2011.
- [8] „Wytyczne standaryzacji pojazdów pożarniczych i innych środków transportu PSP „Komenda Główna SP, Warszawa, 14.04.2011.
- [9] Standard wyposażenia kontenera pożarniczego: Kontener przeciwpowodziowy z pompami do wody zanieczyszczonej typu KPPm, Warszawa (Załącznik nr 10 do „Wytycznych standaryzacji pojazdów pożarniczych i innych środków transportu PSP „Komenda Główna SP” poz. 3), Warszawa, 02.07.2012 .
- [10] Standard wyposażenia kontenera pożarniczego: Kontener przeciwpowodziowy z łodziami typu KPPŁ (Załącznik nr 11 do „Wytycznych standaryzacji pojazdów pożarniczych i innych środków transportu PSP „Komenda Główna SP” poz. 3), Warszawa, 02.07.2012.
- [11] Standard wyposażenia kontenera pożarniczego: Kontener przeciwpowodziowy zaporami typu KPPZ (Załącznik nr 12 do „Wytycznych standaryzacji pojazdów pożarniczych i innych środków transportu PSP „Komenda Główna SP” poz. 3), Warszawa, 02.07.2012.
- [12] Offer for fire-fighting containers <http://zamet-glowno.com> [Retrieved:18-02-2017].
- [13] Offer for hooklift systems <https://www.palfinger.com/en/emea/products> [Retrieved 18-02-2017].
- [14] Offer for hooklift systems <http://www.skibicki.com.pl> [Retrieved :18-02-2017].
- [15] Kowalczyk A., Ołdak M., Markowski T., Żurawski M.: „Klasyfikacja, oznaczenie i podział pojazdów pożarniczych” CNBOP-PIB-0026, Józefów 2015.
- [16] Amphibious LVT-7, [http://dbpedia.org/page/Assault\\_Amphibious\\_Vehicle](http://dbpedia.org/page/Assault_Amphibious_Vehicle) [Retrieved: 20-03-2017].
- [17] Aquatrack, <http://www.army-guide.com/eng/product2854.html> [Retrieved: 20-03-2017].