

Tomasz **MAKOWSKI**
Szymon **PAWŁOWSKI**

CONTROL SYSTEM FOR Z10 CRANE ON MS-40 SUPPORT BRIDGE

Abstract. The subject of matter of this article shows new concept of Z10 crane installed on associated bridge. It is the new version of engineering vehicles which are constructed in OBRUM. The paper presents solutions of control, data analysis and communication. Possibility of using a universal control panel is discussed.

Keywords: Z10 crane, crane control, Universal Control Panel, support bridge, DAGLEZJA-S, MS-40.

1. Z10 CRANE

A new crane, designated Z10, intended for the support bridge laying vehicle MS-40, has been designed and constructed at OBRUM. The support bridge enables crossing medium-sized water and land obstacles by MLC70/110 (STANAG 2021) class vehicles. The bridge laying vehicle enables launching the bridge consisting of bridge span segments over an obstacle up to 40 m wide. The design of the vehicle requires lifting components of the bridge and manipulating them with the crane reaching out as far as 12 m, while control by the operator is maintained as simple as possible. [3]

The design and construction of the Z10 crane was based on OBRUM's experience in designing similar systems used in military vehicles (e.g. recovery vehicle) [1] [2].



Fig 1. MS-40 portable bridge – bridge launching vehicle

2. STRUCTURE OF THE Z10 CRANE CONTROL SYSTEM

The Z10 crane (Fig. 2) is operated hydraulically using proportional valve blocks controlled from a portable control panel. The crane jib is of telescopic design which provides crane radius of 12 m. Due to placing the crane on a vehicle, the capacity of the crane was reduced to 98 N (10 t).

Safe operation of the crane requires some limitations to be effected:

- moment of force,
- lifting capacity,
- overturning moment.

Due to design considerations, including the installation of the crane on a truck chassis, operating limitations resulting from the jib were also applied.

To maintain these limitations, the crane must be provided with a number of dedicated sensors. Electrical and control systems of the crane are presented in Fig. 2.

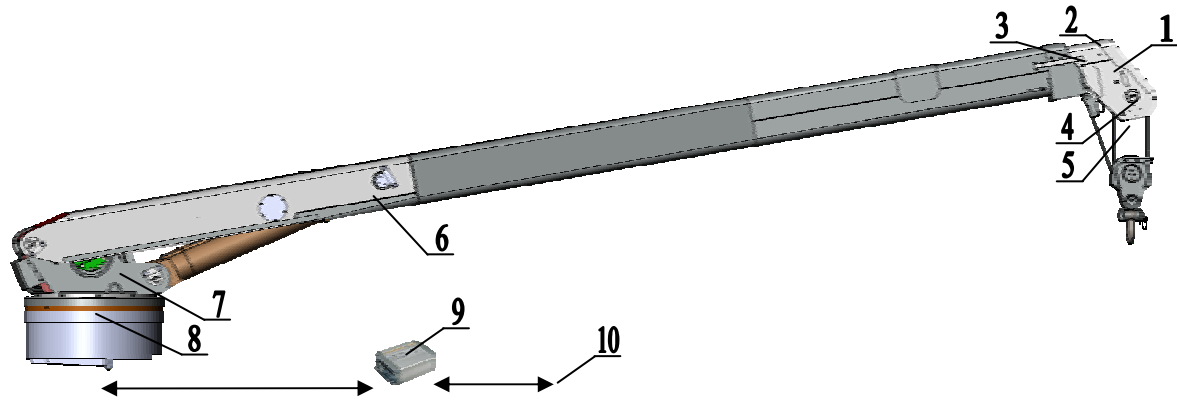

Fig. 2. Z10 crane setup

The crane illustrated in Fig. 2 is fitted with:

- 1 - illuminating lamp – LED lighting,
- 2 - inclinometer – measurement of jib operating angle,
- 3 - link encoder – measurement of jib expansion,
- 4 - pin strain gauge – measurement of force on pulley block,
- 5 - inductive sensor of pulley block lifting to the limit value,
- 6 - pin strain gauge – additional measurement of force acting on jib structure,
- 7 - inductive sensor of cable end,
- 8 - encoder – measurement of jib turning angle,
- 9 - mobile PLC controller.

In addition, the Z10 crane control system makes use of the following:

- 10 - data from other sensors and controllers, such as:
 - a. pressure sensors in support cylinders,
 - b. sensors of hydraulic oil properties,
 - c. inclinometer – vehicle tilt,
 - d. signal from emergency pushbutton,
 - e. operator/controller information exchange interface.

3. CONTROLLING THE Z10 CRANE

The main component of the crane control system is a mobile controller (PLC) [7] which supervises electronic proportional hydraulic valve blocks and enables smooth control of the actuating system – crane movements. The user communicates with the controller by means of a portable universal control panel [4] where, upon selecting appropriate view (panel

screen mask), control settings can be made and operating parameters displayed. When operating the crane, the operator may choose between the main view and secondary view which displays additional, less important information. The universal portable control panel is a proven product used by the Polish Army to operate other OBRUM products, e.g. MS-20. In order to apply uniform control in the various products and use proven solutions, the decision was made to use this control panel with its software adapted to new requirements.

3.1 Mask of the main control panel display

The control panel with the "crane control" mask (Fig. 3) enables controlling the movements of the crane, displaying animations reflecting the crane movements and real time monitoring of the most important operating parameters, such as moment percentage margin, weight of the load suspended on the crane's hook and radius (operating distance). Moreover it is also possible to remotely switch on the lighting, slow down the crane's movement, temporarily actuate an aural signal. In addition, overriding the crane operation limitations is possible in a fully conscious manner, which is recorded by the controller. When crane operating limitations are turned off, appropriate information is displayed on the control panel screen. At the same time an aural signal is sounded and all crane movements are automatically slowed down by 50%.

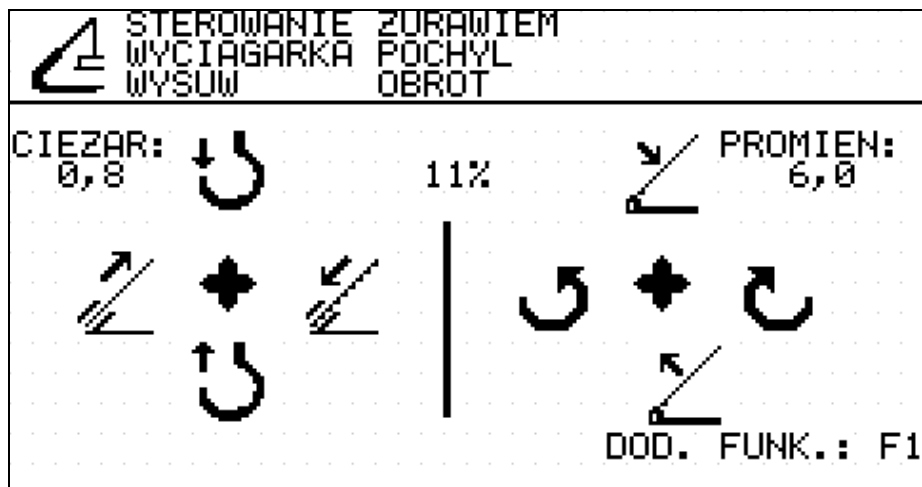

Fig. 3. Example of crane control screen

3.2 Mask of the secondary control panel display

The control panel with the "crane information" mask (Fig. 4) displays information on additional options and operating parameters, such as: tilt angle, crane extension, maximum load liftable under current operating conditions.

INFORMACJE ZURAWIA	
OSTRZEZENIA:	
WYSWIETLENIE INFORMACJI	F1
SPOWOLNIENIE STEROWANIA	F3
WYLACZENIE BLOKADY RUCHOW	F6 Z F10
WLACZENIE BLOKADY RUCHOW	F6 LUB F10
ZALACZENIE REFLEKTORA	F5
PARAMETRY PRACY:	
KAT POCHYLENIA	52
WYSUNIECIE	10,0
OGRANICZNIK UDZWIGU	7,0

Fig. 4. Example of crane information screen display

All views on the universal control panel include, in the top right corner, information on general faults (e.g. low oil level, excessive vehicle inclination, sensor failure).

4. CONCLUSIONS

All signals are analysed by the portable crane controller which monitors limitations, ensures safe operation and conveys information between other vehicle controllers and the operator. Operating parameters of the Z10 crane are displayed on the control panel screen, and an audible signal warns when limits are exceeded. The use of a modern mobile crane controller enabled dynamic adjusting of the lifting capacity to existing operating conditions which provides for a wider range of crane operation. Smooth stopping of movements has also been enforced to ensure safer manipulation of the loads. Emergency pushbuttons enable stopping the entire crane control system.

The Z10 crane control system provides improved operating safety through smooth, proportional control over the actuating mechanisms of the crane and by communicating information to the remote operator in real time. The application of the universal control panel with dedicated screen masks enables transferring information between the operator and the machine in a clear manner and use of the same control panel in various bridges of the Daglezja group.

5. REFERENCES

- [1] Holota M., Stachura B.: Wyroby specjalne OBRUM sp. z o.o. zrealizowane dla potrzeb wojsk lądowych. Zeszyty naukowe WSOWL, No. 1. 2011.
- [2] Jura J.: Wykorzystanie magistrali CAN do sterowania żurawiem K20. Szybkobieżne Pojazdy Gąsienicowe (22) No. 2, 2007, (pp. 67-72). OBRUM Sp. z o.o. Gliwice, 2007.
- [3] Makowski T., Pawłowski Sz., Płatek T.: Układ sterowania mostu przewoźnego wykorzystującego magistralę CAN. Szybkobieżne Pojazdy Gąsienicowe (37) No. 2, 2015, (pp. 49-55). OBRUM Sp. z o.o. Gliwice, 2015.
- [4] Płatek T., Płatek D.: Universal control panel. Szybkobieżne Pojazdy Gąsienicowe (27) No. 1, 2011, (pp. 75-82). OBRUM Sp. z o.o. Gliwice, 2011.
- [5] STANAG 2021 "Military Load Classification of Bridges, Ferries, Rafts And Vehicles", Edition 6, 7 September 2006.
- [6] Ordinance No. 38 of the Minister of Infrastructure of 26 October 2010 on the procedure of MLC classification of new and reconstructed bridges of public roads (Dz.Urz.MI.2010.13.37).
- [7] Mobile controller, <http://www.intercontrol.de/en/off-highway-electronics/products/controller/compact-f-i-59-ios/>, [retrieved: 15 February 2016]
- [8] Żuraw Z10. (OBRUM documents – unpublished). Gliwice, 2015.